

# SCM5B39

## Current Output Modules



### Description

Each SCM5B39 current output module provides a single channel of analog output. The track-and-hold circuit in the input stage can be operated in a hold mode where one DAC can supply many output modules, or a track mode where one DAC is dedicated to each module. In addition to the track-and-hold circuit, each module provides signal buffering, isolation, filtering, and conversion to a high level current output (Figure 1).

Setting of the track or hold mode is controlled by the logic state of WR EN\, module pin 23. When pin 23 is low, the track mode is enabled. If pin 23 is open or high, the hold mode is enabled. The module is designed with a completely isolated computer side circuit which can be floated to  $\pm 50V$  from Power Common, pin 16. This complete isolation means that no connection is required between I/O Common and Power Common for proper operation of the track and hold circuit. For a low state, simply connect pin 23, the Write-Enable pin, to I/O Common, pin 19.

The SCMPB02 and SCMPB06 backpanels allow host computer control of the WR EN\ control line, which allows multiplexing of one host DAC to up to 64 SCM5B39 output modules. During power-up, the output remains at 0mA for 100ms on all models except the SCM5B39-07, which allows the track-and-hold circuit to be initialized.

A special circuit in the output stage of the module provides protection against accidental connection of power-line voltages up to 240VAC on all models except the SCM5B39-07.

### ► Features

- Accepts High Level Voltage or Process Current Input
- Unipolar or Bipolar Current Output
- 1500Vrms Transformer Isolation
- ANSI/IEEE C37.90.1-1989 Transient Protection
- Output Protected to 240VAC Continuous
- 110dB CMR
- 400Hz Signal Bandwidth
- $\pm 0.03\%$  Accuracy
- $\pm 0.005\%$  Linearity
- CSA Certified, FM Approved, CE Compliant
- Mix and Match SCM5B Types on Backpanel

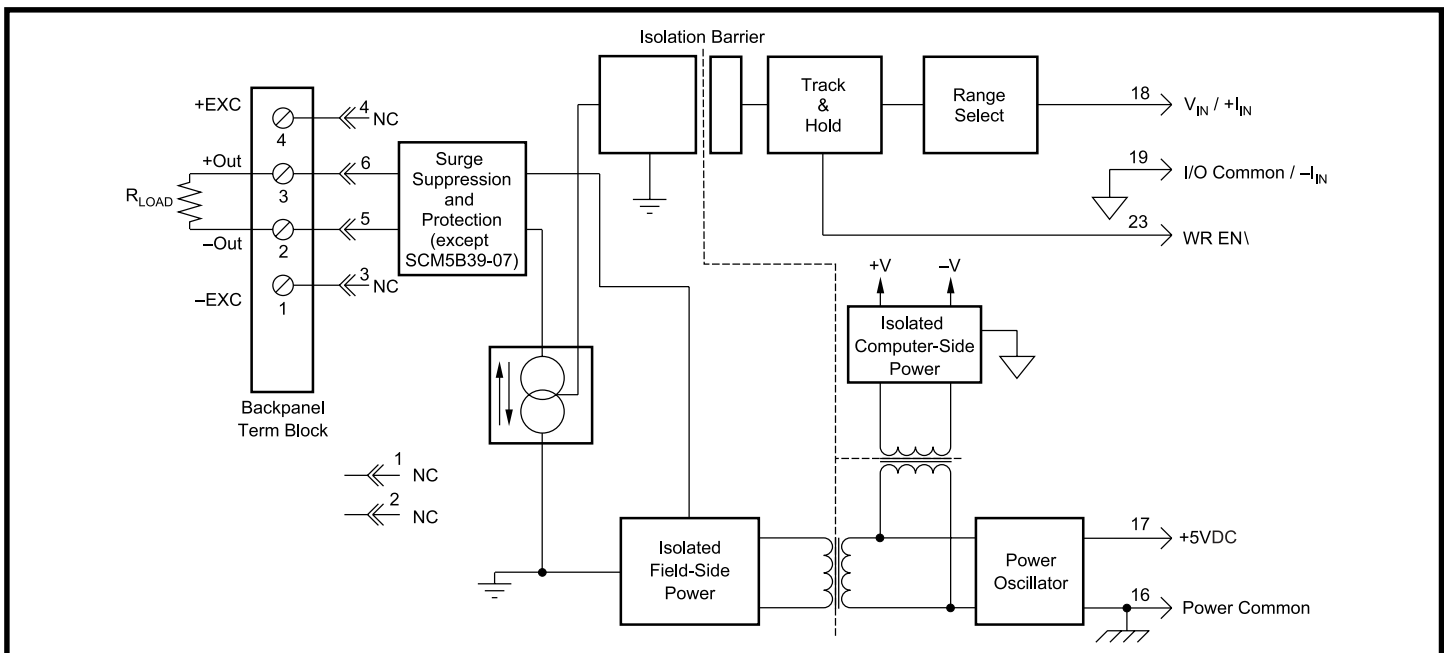

Figure 1: SCM5B39 Block Diagram

**Specifications** Typical at  $T_A = +25^\circ\text{C}$  and +5V power

| Module   | Unipolar Output Current<br>SCM5B39-01,-02,-03,-04,-05                                     | Bipolar Output Current<br>SCM5B39-07  |
|--|---|---|
| Input Voltage Range                            | $\pm 5\text{V}$ or 0V to +5V  | $\pm 10\text{V}$  |
| Input Current Range (-05)                      | 0 to 20mA   | N/A   |
| Input Voltage Maximum                          | $\pm 36\text{V}$ (no damage)  | *   |
| Input Current, Maximum (-05)                   | 75mA (no damage)  | N/A   |
| Input Resistance                               | 50M $\Omega$  | 2M $\Omega$   |
| Input Resistance (-05)                         | 20 $\Omega$   | N/A   |
| Output Current Range                           | 0 to 20mA or 4 to 20mA  | $\pm 20\text{mA}$   |
| Over Range Capability                          | 10%   | *   |
| Output Compliance Voltage<br>(Open Circuit)    | 22VDC   | $\pm 15\text{VDC}$  |
| Load Resistance Range                          | 0 to 650 $\Omega$<br>(0 to 750 $\Omega$ for Power Supply<br>Voltage greater than 4.95VDC) | 0 to 450 $\Omega$<br>(0 to 500 $\Omega$ for Power Supply<br>Voltage greater than 4.95VDC) |
| Output I Under Fault, max<br>Output Protection | 26mA  | *   |
| Continuous                                     | 240Vrms max   | N/A   |
| Transient                                      | ANSI/IEEE C37.90.1-1989   | N/A   |
| CMV, Output to Input                           |   |   |
| Continuous                                     | 1500Vrms max  | *   |
| Transient                                      | ANSI/IEEE C37.90.1-1989   | *   |
| CMR (50Hz or 60Hz)                             | 110dB   | *   |
| NMR (-3dB at 400 Hz)                           | 40dB per Decade<br>above 400Hz  | 40dB per Decade<br>above 275Hz  |
| Accuracy                                       | $\pm 0.03\%$ Span   | $\pm 0.05\%$ Span   |
| Nonlinearity                                   | $\pm 0.005\%$ Span  | $\pm 0.03\%$ Span   |
| Stability                                      |   |   |
| Zero   | $\pm 0.5\mu\text{A}/^\circ\text{C}$   | *   |
| Span   | $\pm 20\text{ppm}/^\circ\text{C}$   | $\pm 40\text{ppm}/^\circ\text{C}$   |
| Noise  |   |   |
| Output Ripple, 1kHz<br>bandwidth               | 10 $\mu\text{A}$ p-p  | *   |
| Bandwidth, -3dB                                | 400Hz   | 275Hz   |
| Rise Time, 10 to 90% Span                      | 1.0ms   | 1.2ms   |
| Sample and Hold                                |   |   |
| Output Droop Rate                              | 40 $\mu\text{A}/\text{s}$   | *   |
| Acquisition Time                               | 50 $\mu\text{s}$  | *   |
| Track-and-Hold Enable Control                  |   |   |
| Max Logic "0"                                  | +0.8V   | *   |
| Min Logic "1"                                  | +2.4V   | *   |
| Max Logic "1"                                  | +36V  | *   |
| Input Current, "0"                             | 0.5 $\mu\text{A}$   | *   |
| Power Supply Voltage                           | +5VDC $\pm 5\%$   | *   |
| Power Supply Current                           | 170mA   | 130mA   |
| Power Supply Sensitivity                       | $\pm 0.5\mu\text{A}/\%$ typ   | *   |
| Mechanical Dimensions<br>(h)(w)(d)             | 2.28" x 2.26" x 0.6"<br>(58mm x 57mm x 15mm)  | *   |
| Environmental                                  |   |   |
| Operating Temp. Range                          | -40 $^\circ\text{C}$ to +85 $^\circ\text{C}$  | *   |
| Storage Temp. Range                            | -40 $^\circ\text{C}$ to +85 $^\circ\text{C}$  | *   |
| Relative Humidity                              | 0 to 95% Noncondensing  | *   |
| Emissions                                      | EN50081-1, ISM Group 1,<br>Class A (Radiated, Conducted)                                  | *   |
| Immunity                                       | EN50082-1, ISM Group 1,<br>Class A (ESD, RF, EFT)   | *   |

## NOTES:

\* Same as -01, -02, -03, -04, -05 modules.

(1) CSA Certification and FM Approval Pending.

**Ordering Information**

| Model                     | Input Range  | Output Range   | Bandwidth |
|---------------------------|--------------|----------------|-----------|
| SCM5B39-01                | 0V to +5V    | 4mA to 20mA    | 400Hz     |
| SCM5B39-02                | -5V to +5V   | 4mA to 20mA    | 400Hz     |
| SCM5B39-04                | -5V to +5V   | 0mA to 20mA    | 400Hz     |
| SCM5B39-05                | 0mA to 20mA  | 0mA to 20mA    | 400Hz     |
| SCM5B39-07 <sup>(1)</sup> | -10V to +10V | -20mA to +20mA | 275Hz     |

Refer to SCM5B392 specifications, p.27, for additional current output models.